

LPG VANE PUMP 5HP

WLVP-1000

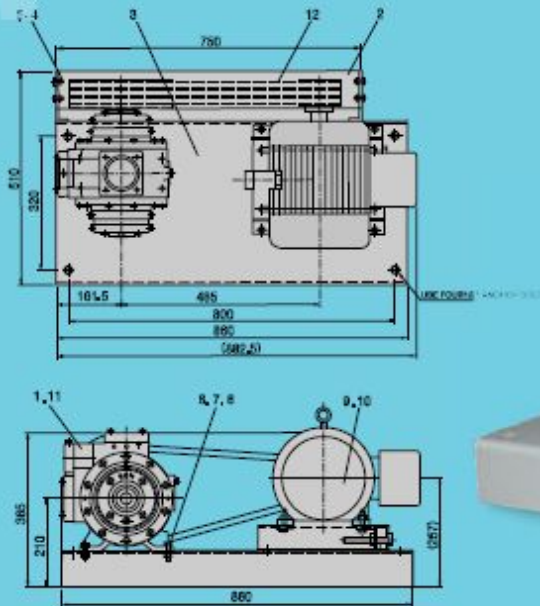

MATERIAL

NO.	PART NAME	MATERIAL	NO.	PART NAME	MATERIAL
1	PUMP Ass'Y	GCD450	7	HEX NUT	SCM415
2	PULLEY COVER ASS'Y	SS41	8	SPRING WASHER	SCM415
3	BASE PLATE ASS'Y	SS41	9	MOTOR	S.T.D
4	HEX BOLT	S45C	10	MOTOR PULLEY	S.T.D
5	HEX NUT	S45C	11	PUMP PULLEY	S.T.D
6	HEX BOLT	SCM415	12	V-BELT	S.T.D

SPECIFICATION

SERVICE FLUID	LPG, NH ₃
SUCTION FLANGE	65A JIS20K (PT 2-1/2")
DISCHARGE FLANGE	50A JIS20K (PT 2)
MIN.RPM	420 RPM
MAX.RPM	950 RPM
CAPACITY(AT 950 RPM)	up to 341 LIT/MIN
MIN.TEMP.	-32 °c
MAX.TEMP.	107 °c
MAX.WORKING PRESSURE	2.76 MPa
MAX.DIFERENTIAL PRESSURE	0.86 MPa
MOTOR	5hp, dll G4, 220/380V 3P
MOTOR PULLEY	B3, 4"
PUMP PULLEY	B3, 10"
V-BELT	B60
PAINT (하도)	POLY-URETHANE (GREY)
PAINT (상도)	6.2BG 5.8/1.7

Application :

To transfer liquid LPG(NH₃) from tank lorry to tank

• Hydrostatic test pressure :
2.94 MPa

• Pneumatic test pressure :
2.16 MPa

• Fluid : LPG, NH₃

* REMARK : 1.MATERIAL IS TO BE CHANGED IN CASE OF NH₃ / 2.PLEASE CONTACT US WHEN APPLYING FOR OTHER GASES

*참고 : 1.암모니아용일 경우 일부 재질을 변경함. / 2.다른 가스 용도로 사용할 경우 당사로 연락바람.